

| FOUNDATION REINFORCING SCHEDULE |     |      |          |                    |              |
|---------------------------------|-----|------|----------|--------------------|--------------|
| ASTM 615 - GRADE 60             |     |      |          |                    |              |
| MARK                            | QTY | SIZE | LENGTH   | BENDING            | WEIGHT (LBS) |
| VR1                             | 48  | #4   | 3' - 4"  | 2' - 4"   11' - 0" | 107          |
| HR1                             | 32  | #5   | 11' - 6" | 11' - 6"           | 384          |
| HR2                             | 96  | #4   | 2' - 6"  | 2' - 6"            | 160          |
| HR3                             | 16  | #4   | 11' - 6" | 11' - 6"           | 123          |
| APPROACH REBAR                  |     |      |          |                    |              |
| AR1                             | 24  | #4   | 11' - 6" | 11' - 6"           | 184          |
| AR2                             | 24  | #4   | 9' - 6"  | 9' - 6"            | 152          |
| Total Weight:                   |     |      |          |                    | 1110         |

**GENERAL NOTES**

- Foundation shown is designed for soils with a minimum bearing capacity of 3000 psf and adequate drainage. If soil conditions do not meet these requirements, adjust foundation or soil as required.
- In areas of the country where there is severe freezing, increase the depth of the foundation so that the bottom extends below the frost line, or provide a minimum of 12" free draining granular material to prevent frost heave.
- N.I.S.T. H-44 requires that on the entrance and exit ends of a vehicle scale, there shall be a straight approach that is:
  - At least the width of the platform.
  - The length of at least one-half the length of the platform but not required to be more than 40ft, and
  - Any slope in the remaining portion of the approach shall ensure ease of vehicle access, ease for testing purposes, and drainage away from the scale.
- N.I.S.T. H-44 requirements and local weights and measures regulations may require installation parameters somewhat different than illustrated on this plan. In order to insure compliance, consult the local Fairbanks service office prior to installation.
- Refer to manual for all installation and operation instructions.
- Fairbanks does not recommend using foundation or ground installed guide rails along the sides of the truck scale platform. Damage may occur to the scale if the vehicle hits the guide rail, transferring damaging forces to the platform and the checking system. Usage of this style guide rail will void the product warranty. If guide rails are necessary, please use fairbanks accessory rub rails.
- A minimum of 24" of clearance is required on both sides of the scale in order to access load cells, electronics, and checking hardware.

**REINFORCING STEEL NOTES**

- Reinforcing steel are to be ASTM 615, Grade 60 or equal. Bend bars cold to conform with required details. Rebar shall be free of all mud, debris, cement grout, loose rust, grease and oil that would impair bonding. Space bars properly and tie securely in position before pouring concrete. Tack welding of bars is prohibited.
- Rebar cover:
  - Concrete cast against earth: 3"
  - Formed concrete exposed to earth or weather: 2"
  - Cover at termination end of rebar: 3"

**GROUNDING AND ELECTRICAL NOTES:**

- Install (2) 3/4" x 8'-0" long ground rods to project 4" above the surface. Two ground rods are supplied with scale.
  - One for grounding Intaloxig Power Supply. Position the ground rod to match the chosen location for the PPS. The PPS may be located at any interior section, and on either side of the scale.
  - One for grounding scale weighbridge. Place within 3ft of scale, at any convenient location. The power supply ground must be separate from weighbridge ground.
- Install minimum 1 1/2" conduit for cable from junction box to scalehouse. Conduit to extend 2" above the surface (not supplied by Fairbanks Scales). Position near PPS.
- If alternating current (AC) is required near the scale, it shall not run closer than 36" in parallel with any load cell or other signal carrying cable.

| FOUNDATION CONCRETE |               |  |
|---------------------|---------------|--|
| 3500 PSI MINIMUM    |               |  |
| LOCATION            | QTY (CU. YDS) |  |
| PIERS               | 6.75          |  |
| WASHOUT             | 8.25          |  |
| APPROACHES          | 7.50          |  |
| TOTAL CONCRETE      | 22.25         |  |
| MINIMUM EXCAVATION  | 19.00         |  |

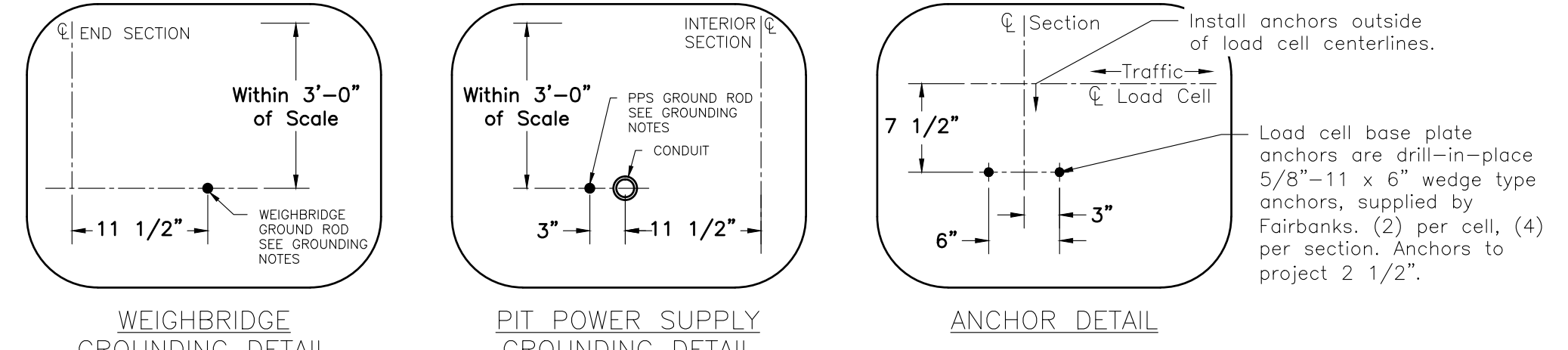
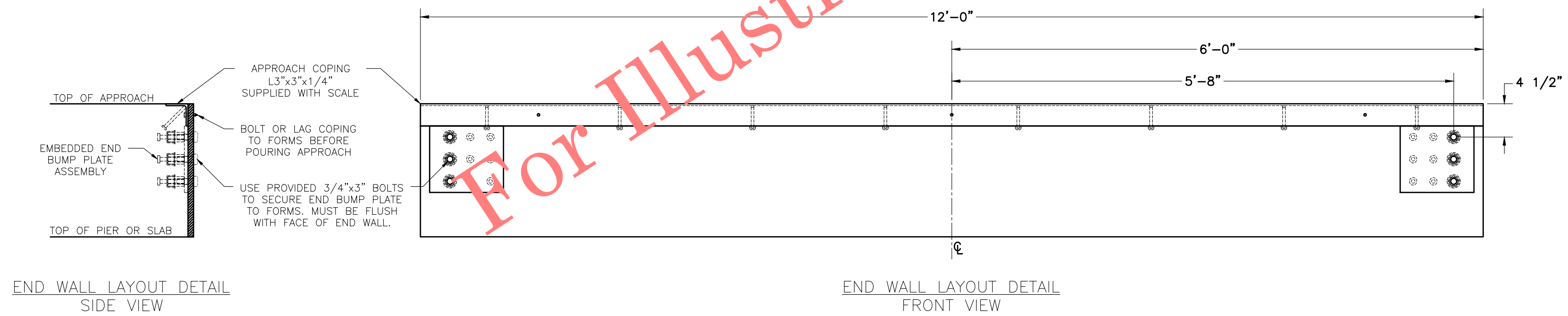

70' x 11'

Trident 80k Precast Undermount  
80,000lb CLC, 100ton Capacity

**FAIRBANKS**

SCALE: NTS DRAWING NO: 3/17/16 CHECKED: [ ]  
SHEET: 1 OF 1 DATE: 3/17/16 APPROVED: [ ]  
DRAWING NUMBER: D-A163170-AP15 REV: [ ]

MODEL: PLT-6030-080-A11-070